

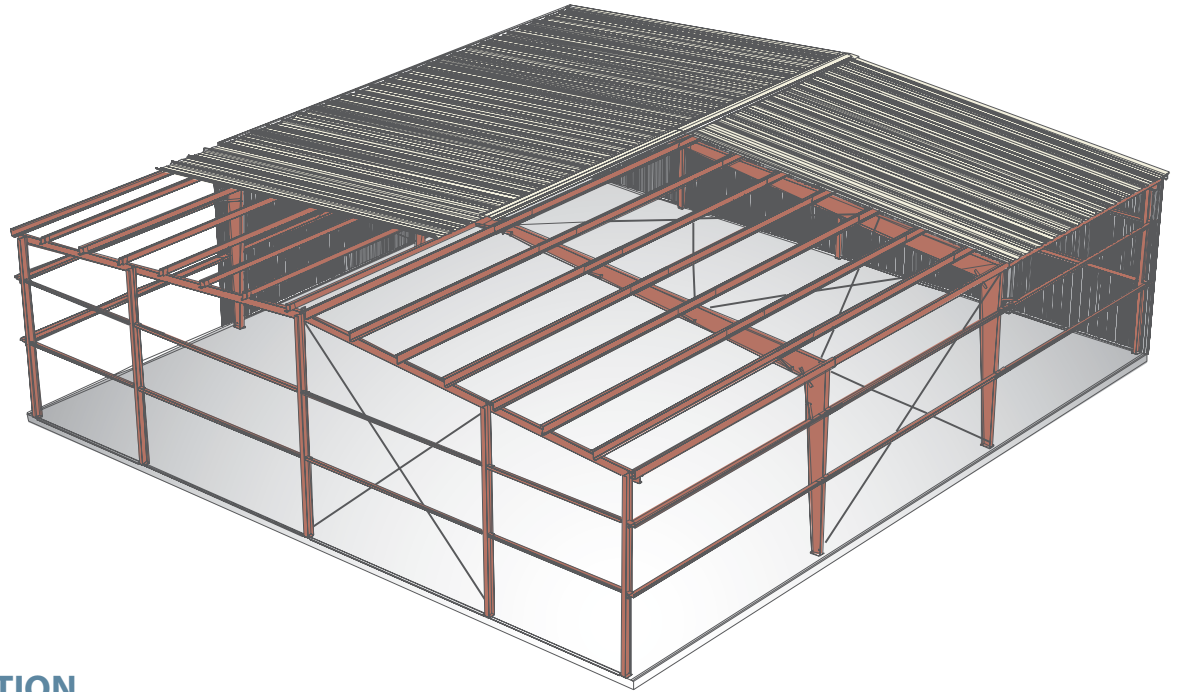

- Gable Symmetrical
- Gable Unsymmetrical
- Single Slope
- Long Bay® System
- Lean-to
- Hybrid Structures
- Crane Buildings
- Aviation Facilities

Gable Symmetrical



PRODUCT DESCRIPTION

Gable Symmetrical: A ridged (double slope) building in which the ridge is in the center of the building.

- Gable:** The triangular portion of the endwall from the level of the eave to the ridge of the roof.
- Gauge:** NA
- Finish:** Red Oxide Primer
- Usage:** Low rise construction
- Limitations:** Support widths from 10' to 600' or more  
Support height from 10' to 100'  
Support clear spans up to 250' or more  
Support roof slopes of ¼ : 12 up to 12 : 12

Frame Types Available

Clear Span Main Frame

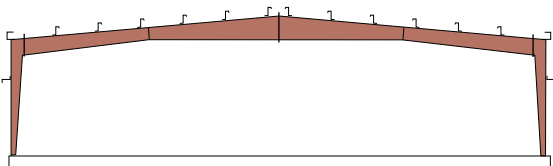

Modular Span One Interior Column

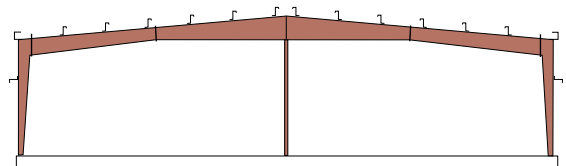

Modular Span Two Interior Columns

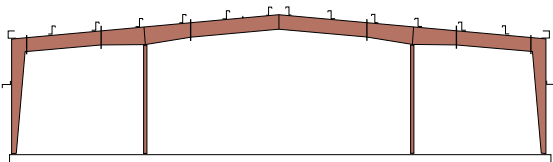

Modular Span Three Interior Columns

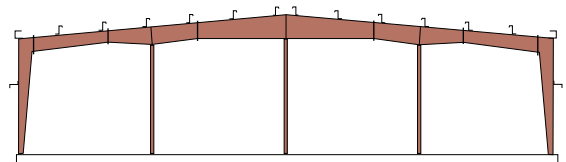

## Feature

Designers have the capability of arranging sidewall columns that are straight or columns with the more economical tapered section.

NCI fabricates all main framing in accordance with the company's strict AISI quality certification guidelines.

Interior support columns available as either pipe sections or H sections.

NCI frames come with welded subassemblies. Roof purlin support plates and wall girt support plates are factory welded to the main frames.

Purlins are supported laterally by the welded plates.

NCI furnishes all structural bolts with a corrosion protective plating.

Frames are prefabricated as much as possible.

Endwall frames can be simple post and beam type construction, or can be built with a full interior type main frame to accommodate future expansion.

Asymmetrical Shape.

## Benefit

Flexible design providing for maximum utilization of interior space.

The benefit of the quality fabrication practice of NCI is the reduction in building assembly labor, and subsequently lower installation cost.

Wider buildings are more economical.

Saves installation time and increases the overall stiffness of the building.

Reduces the amount of purlin roll experienced under heavy loading.

Improves the appearance of the building and helps to speed up installation process, and no more rusted bolts to contend with.

Eliminates costly field work needed to "customize" the frames for specific building configurations.

Endwalls are furnished in a variety of configurations, again with the flexibility to meet any need.

Economical savings on material costs.



- Gable Symmetrical
- Gable Unsymmetrical
- Single Slope
- Long Bay® System
- Lean-to
- Hybrid Structures
- Crane Buildings
- Aviation Facilities

Gable Unsymmetrical

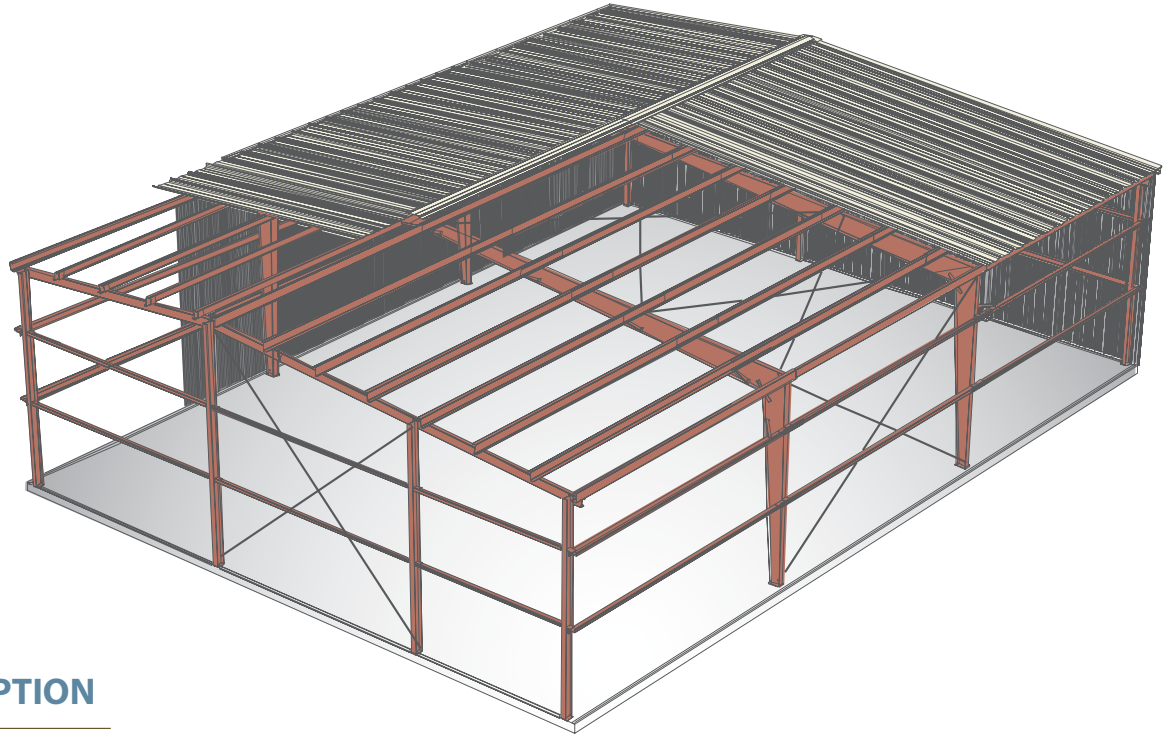

PRODUCT DESCRIPTION

Gable Unsymmetrical: A ridged (double slope) building in which the ridge is off-center.

- Gable:** The triangular portion of the endwall from the level of the eave to the ridge of the roof.
- Gauge:** NA
- Finish:** Red Oxide Primer
- Usage:** Low rise construction
- Limitations:** Support widths from 10' to 600' or more  
Support height from 10' to 100'  
Support clear spans up to 250' or more  
Support roof slopes of ¼ : 12 up to 12 : 12

Frame Types Available

Clear Span Main Frame

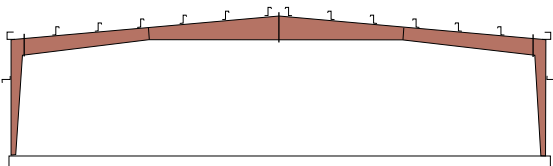

Modular Span One Interior Column

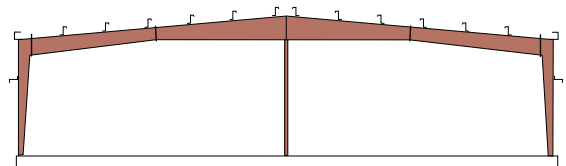

Modular Span Two Interior Columns

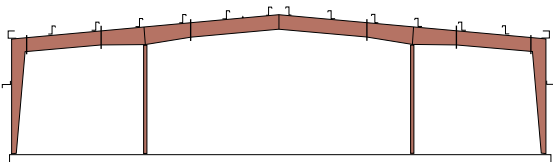

Modular Span Three Interior Columns

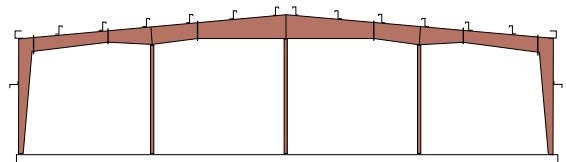

## Feature

Designers have the capability of arranging sidewall columns that are straight or columns with the more economical tapered section.

NCI fabricates all main framing in accordance with the company's strict AISI quality certification guidelines.

Interior support columns available as either pipe sections or H sections.

NCI frames come with welded subassemblies. Roof purlin support plates and wall girt support plates are factory welded to the main frames.

Purlins are supported laterally by the welded plates.

NCI furnishes all structural bolts with a corrosion protective plating.

Frames are prefabricated as much as possible.

Endwall frames can be simple post and beam type construction, or can be built with a full interior type main frame to accommodate future expansion.

Asymmetrical shape.

## Benefit

Flexible design providing for maximum utilization of interior space.

The benefit of the quality fabrication practice of NCI is the reduction in building assembly labor, and subsequently lower installation cost.

Wider buildings are more economical.

Saves installation time and increases the overall stiffness of the building.

Reduces the amount of purlin roll experienced under heavy loading.

Improves the appearance of the building and helps to speed up installation process, and no more rusted bolts to contend with.

Eliminates costly field work needed to "customize" the frames for specific building configurations.

Endwalls are furnished in a variety of configurations, again with the flexibility to meet any need.

Economical savings on material costs.



- Gable Symmetrical
- Gable Unsymmetrical
- Single Slope
- Long Bay® System
- Lean-to
- Hybrid Structures
- Crane Buildings
- Aviation Facilities

Single Slope

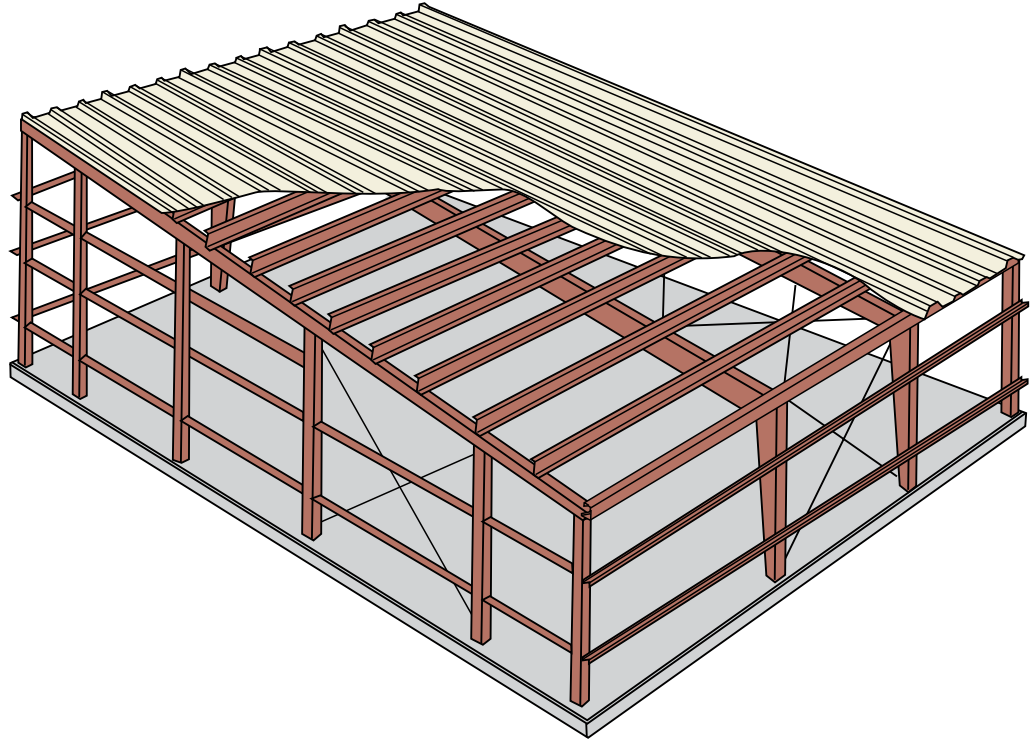

PRODUCT DESCRIPTION

Single Slope: A stand alone building with a sloping roof in one plane. The slope is from one wall to the opposite wall.

Usage: Low rise construction

Frame Types Available

Clear Span

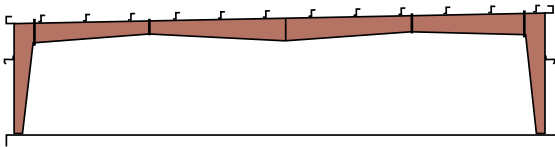

Modular One Interior Column

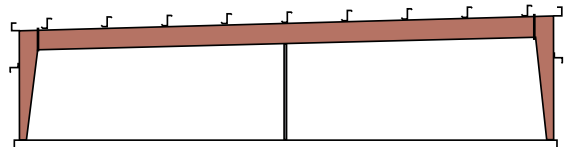

Modular Two Interior Columns

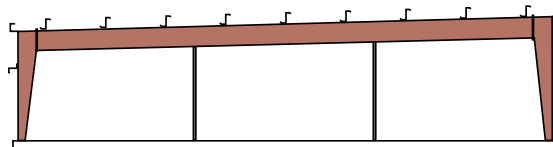

## Long Bay® System

Gable Symmetrical  
 Gable Unsymmetrical  
 Single Slope  
 Long Bay® System  
 Lean-to  
 Hybrid Structures  
 Crane Buildings  
 Aviation Facilities

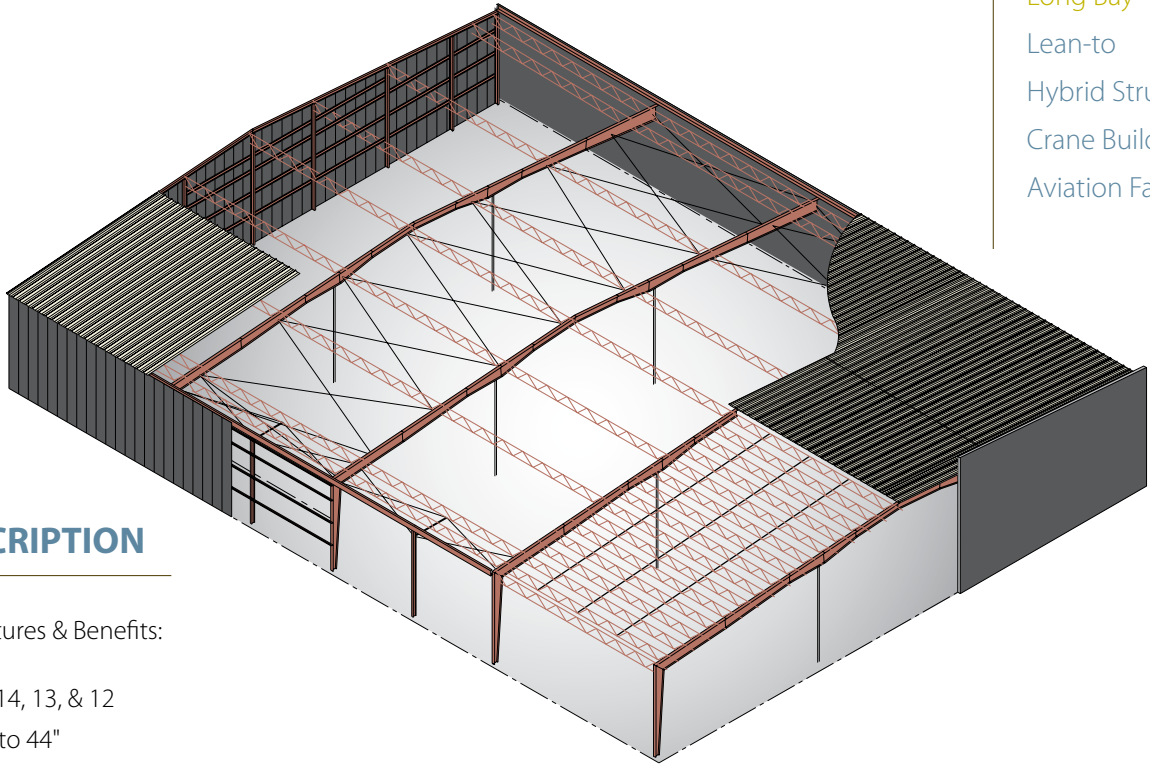

## PRODUCT DESCRIPTION

### Long Bay® System Features & Benefits:

<b>Gauge:</b>	16, 14, 13, & 12
<b>Depths:</b>	12" to 44"
<b>Finish:</b>	Red or gray oxide primer available
<b>Lengths:</b>	Matches bay length

### Why use the Long Bay® System?

- Economical bay spacing up to 65'
- Quicker and more economical installation
- Available with machine seamed standing seam roof - the industry's leading standing seam panel

### Industry's Leading Standing Seam Panel

- Optimum bay spacing & column locations
- Can mix with traditional purlins
- Use with B deck, built up and single ply
- Design flexibility (can be used with hardwall systems)

### Long Bay® System's Features

- Available with up to 65' bays
- Assembled with screw guns
- Can be used with 22 gauge "B" deck
- Uses tubular sections
- Constructed using square channel web members

### Ease of Installation

- Typical metal building procedures - bolting and/or welding
- Fewer rows of bridging needed with the Long Bay® system
- Stiffer than traditional joist
- Lighter than traditional joist
- Attaches with self drilling screws

### Benefits to the Builder

- Now competes in the Long Bay® market
- Eliminates fluctuating bar joist price/delivery
- Better control over cost and delivery schedule

### Rigorous Testing

- Gravity loads
- Uplift loads
- Stress
- Test conducted with standing seam roofs and through fastened panels
- Available with Factory Mutual certification

### Spans & Loads

- Bay spacing can span 65'
- Custom-designed per your specifications and local government compliance codes
- Custom-fabricated to accommodate specified wind loads
- Unlimited building widths and lengths

- Gable Symmetrical
- Gable Unsymmetrical
- Single Slope
- Long Bay® System
- Lean-to
- Hybrid Structures
- Crane Buildings
- Aviation Facilities

Long Bay® System (cont.)

Details

Long Bay® Spandrel at Main Frame (w/ Masonry Wall)

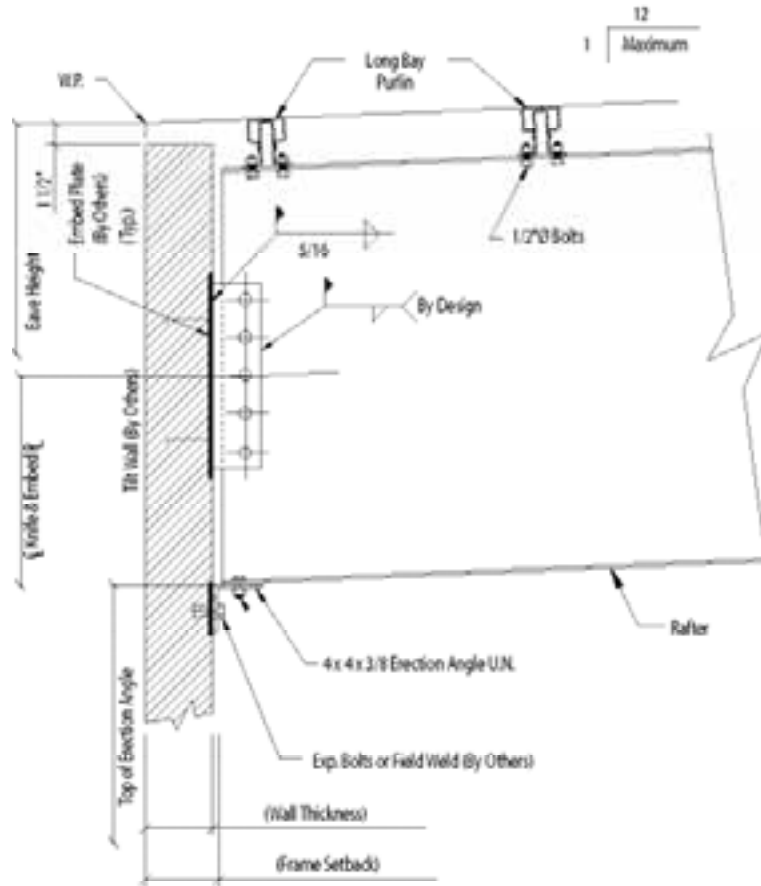

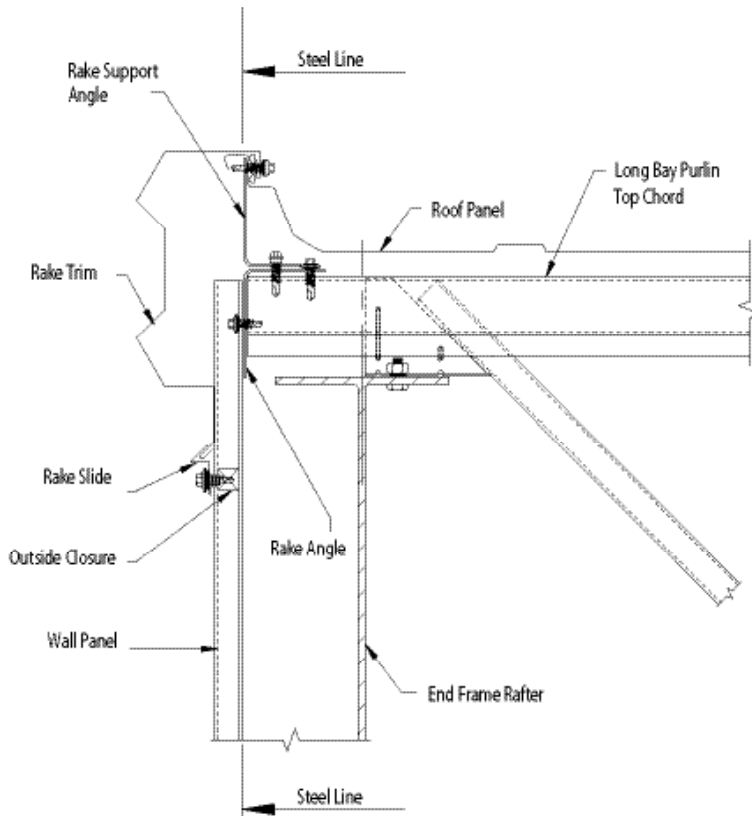

Long Bay® Purlin with Double-Lok® Starting Rake Condition (On-Module)

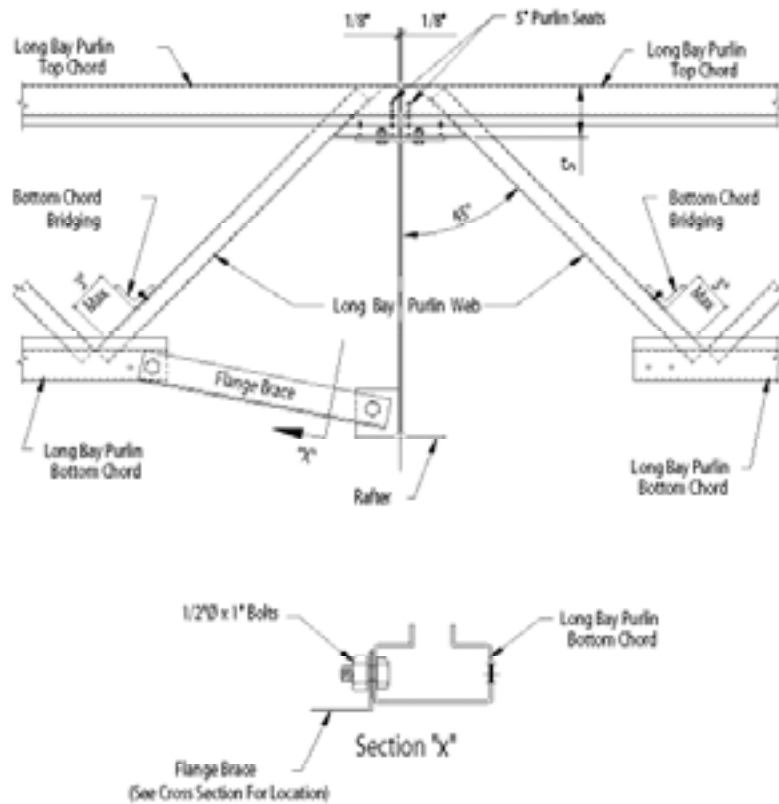

Flange Brace Connection





- Gable Symmetrical
- Gable Unsymmetrical
- Single Slope
- Long Bay® System
- Lean-to
- Hybrid Structures
- Crane Buildings
- Aviation Facilities

Long Bay® System (cont.)

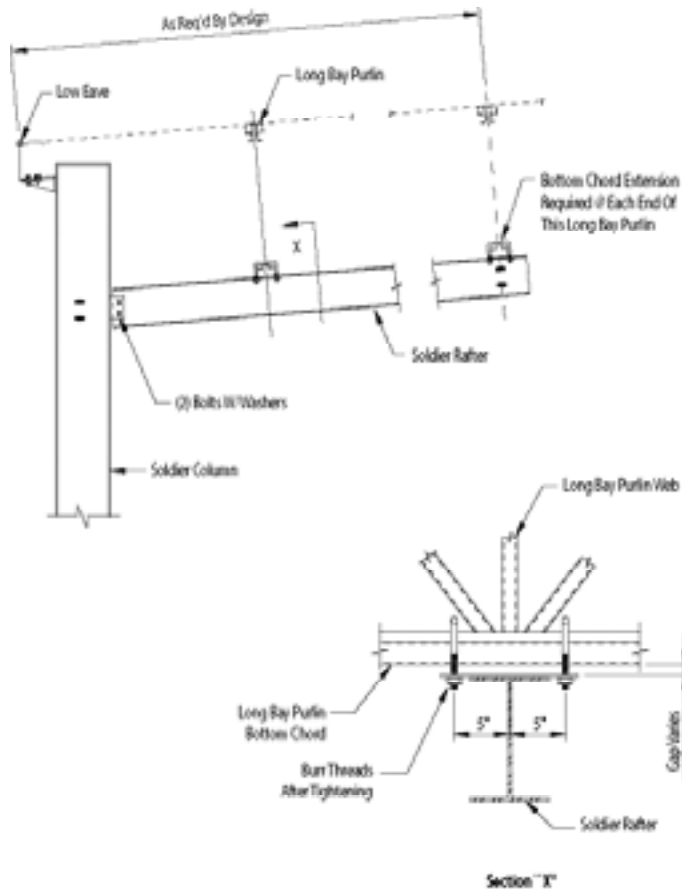

Long Bay® Connection at Low Side Soldier Column

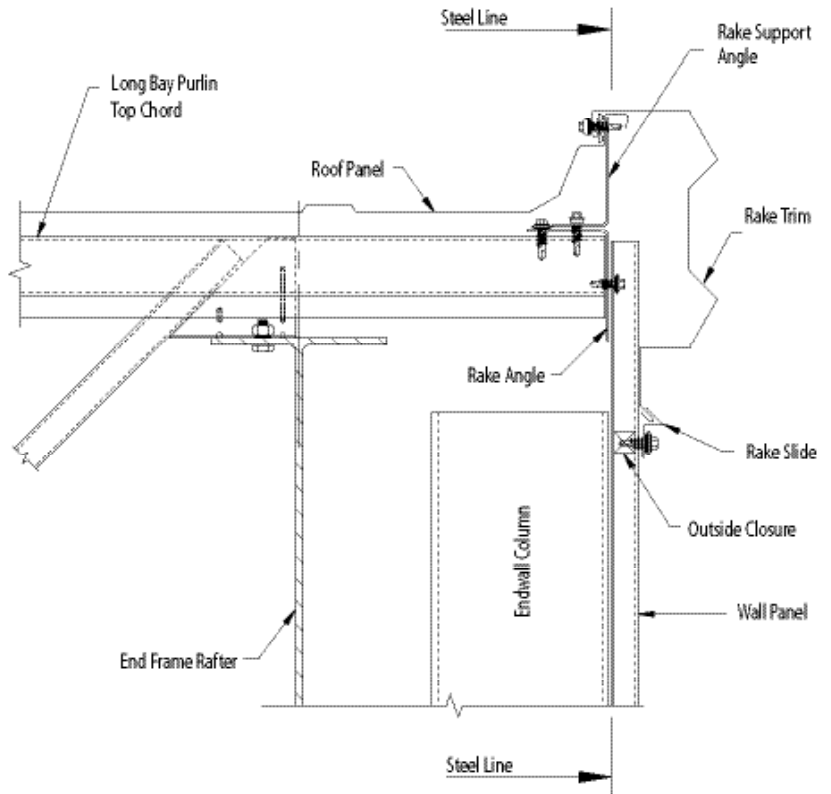

Long Bay® Purlin with Double-Lok® Ending Rake Condition (On-Module)

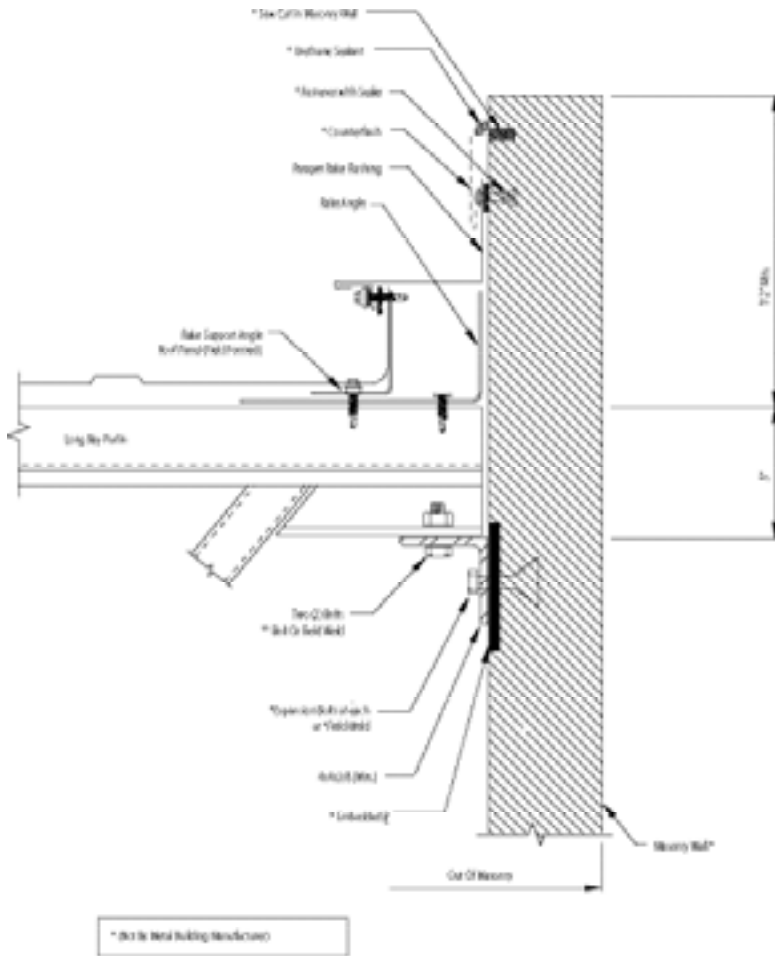

Long Bay® Purlin at Masonry Parapet

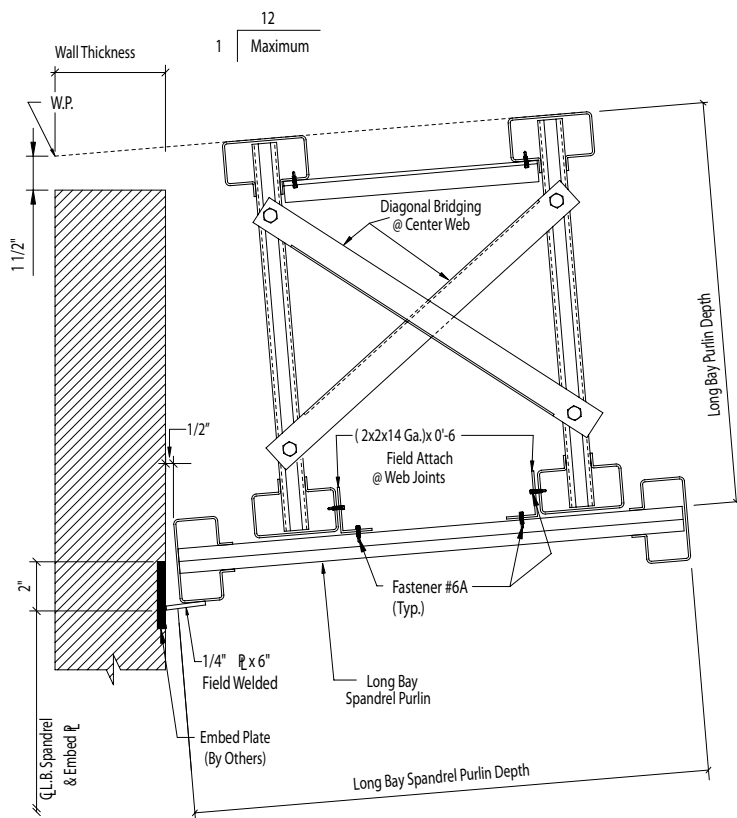

Long Bay® Spandrel Purlin at Masonry Sidewall



- Gable Symmetrical
- Gable Unsymmetrical
- Single Slope
- Long Bay® System
- Lean-to
- Hybrid Structures
- Crane Buildings
- Aviation Facilities

Lean-to

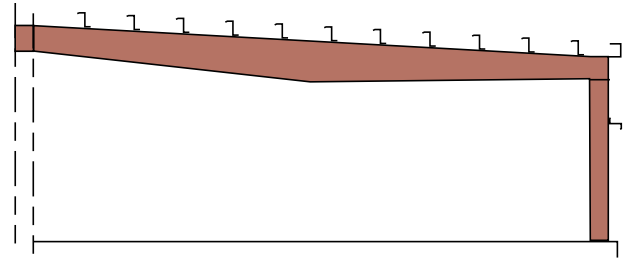
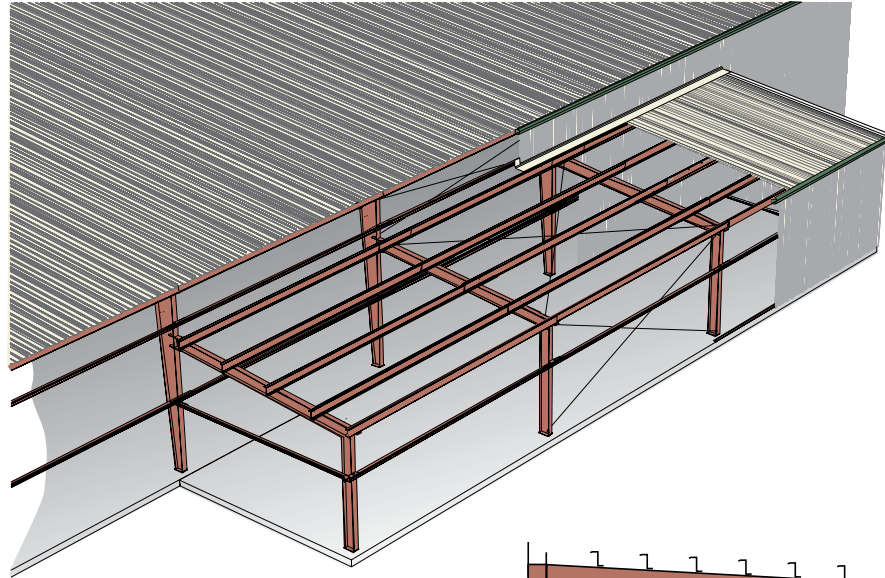

PRODUCT DESCRIPTION

Lean-to: Ideally suited to give you that extra space you need alongside your building. The Lean-to ties in at the eave of your building or below the eave and can provide a variety of uses...from just a covered area to a completely enclosed addition to your building.

**Gauge:** NA

**Finish:** Red Oxide Primer

**Usage:** Low rise construction

**Limitations:** A structure having only one slope and depending upon another structure for partial support. A Lean-to can be located at eave or below eave of the supporting structure.

## Hybrid Structures



Gable Symmetrical  
 Gable Unsymmetrical  
 Single Slope  
 Long Bay® System  
 Lean-to  
 Hybrid Structures  
 Crane Buildings  
 Aviation Facilities

## PRODUCT DESCRIPTION

**Hybrid Structures:** Our hybrid structures blend the efficiency of metal building system construction with the strength of conventional steel. This means we meet your heavy duty requirements at the most reasonable cost possible.

**Box Girders:** Precision box girders that can be used to support cranes or other heavy loads and provide open spans of 70 feet or more between columns.

**Gauge:** NA

**Finish:** Red Oxide Primer

**Usage:** We can design, engineer, and manufacture virtually everything required for hybrid structures, no matter how large or complex. We have complete in-house engineering and computer design groups dedicated to hybrid structures. Manufacturing facilities include roll forming, welding, and shearing equipment, and continuous-run processing for uniform quality and measurement accuracy. Our highly automated equipment can produce custom-designed and standard components with equal precision.

**Limitations:** All Hybrid Structures are treated uniquely, limitations can change based on the complexity of the project.

- Gable Symmetrical
- Gable Unsymmetrical
- Single Slope
- Long Bay® System
- Lean-to
- Hybrid Structures
- Crane Buildings
- Aviation Facilities

## Crane Buildings

### PRODUCT DESCRIPTION

**Crane Buildings:** The building crane is a complex structural system consisting of the crane with trolley and hoist, crane rails and crane runway beams, structural supports, stops and bumpers.

**Crane Type:**

- Bridge Cranes - Top running and Underhung
- Monorail
- Jib
- Stacker
- Gantry

**Note:** We specialize in crane buildings and have furnished the largest crane systems in the industry. We routinely handle 100-ton crane buildings and more.



## Aviation Facilities



### PRODUCT DESCRIPTION

**Aviation Facilities:** Aircraft hangars are individually engineered to meet specific requirements and are flexible enough to satisfy even the most complex aviation need. The hangars may be designed using gable symmetrical, gable unsymmetrical or single slope structural systems.

**Advantages:**

- Design flexibility
- Fast, easy construction
- Low maintenance
- Energy efficiency

**Usage:** Clear span design provides column-free interiors for wide open floor space and eave heights that can accommodate today's larger aircraft. The structures allow for a variety of door options including bi-fold, bi-parting, and stack leaf designs.

**Note:** We have pioneered the use of extra wide clear-span structures to handle today's largest jet aircraft fleet.